

NEW PRODUCT INFORMATION

XLP 504 WITH LTSA APPLICATOR

NOVEX 
SOLUTIONS

Table of contents

1. Release information	2
2. Description of the product and its benefits	3
3. Specifications.....	4
4. Models and options.....	5
4.1. XLP 504 with LTSA applicator	5
4.2. LTSA upgrade kit for XLP 504	5
4.3. Application activation methods	6
5. Key applications.....	7
6. Family positioning	7
7. Item numbers and prices.....	7
7.1. Product.....	7
7.2. Options.....	7
7.3. Demo unit.....	7
8. State at delivery	8
9. Availability	8
10. Contact	8

1. Release information

Release number:	F1273
Release date:	April 2018
Document version:	V1.0
Product group:	Hardware
Product:	Printers
Backwards compatibility:	Yes
Release Subject:	Release XLP 504 with LTSA applicator

2. Description of the product and its benefits

The XLP 504 Label Printer is available with an LTSA (“Light Touch Stepper Applicator”) label applicator. The solution includes an XLP 504 printer with internal rewriter/dispenser and LTSA. The XLP 504 with LTSA is available for all three print resolutions: 203, 300 and 600 dpi. With a label size of up to 80 x 80 mm and a max. stroke length of 190 mm, the XLP 504 with LTSA is a perfect fit for multiple applications for the **top labeling** of products. It can be used both for stopped and moving products.



Key benefits

The XLP 504 with LTSA Applicator is an **all-in-one semi-automatic Print & Apply solution** for manual and low volume product identification.

- **Easy configuration**
 - LTSA is connected to XLP with one connector only
 - control and settings through XLP firmware
 - flexible dispensing edge for smooth feed of the label to the LTSA label pad
 - no compressed air needed – the LTSA is motor driven

- **Smooth application**
 - controlled movement of LTSA to product enables high application accuracy
 - spring loaded label pad softly touches products – reduced risk of product damages

- **Flexible integration**
 - for applications with manual product handling
 - integration in conveyor systems with moving products
 - easy to move to different production areas

3. Specifications

FEATURES	
XLP 504	
Special version for LTSA Print resolution 203/300/600 dpi Including internal rewind and dispensing edge Specifications as per XLP 504	
LTSA	
Application	Top application
Label size (W x L)	Min. 30 x 30 mm Max. 80 x 80 mm
Stroke length	Max. 190 mm
Min. distance to product detection (home position to top of the product)	30 mm
Capacity indication	Up to 50 labels/min.
Product speed	Up to 35 m/min. during application of label
Apply edge	90° ± 3°
Dimensions	230 x 392 x 120 mm (W x H x D)
Activation methods	Start trigger by operator through e.g footswitch (single start connector) Start trigger by product start sensor (Sub-D connector on optional I/O board)
Firmware	
V7.75, for details please refer to Standard Release F1277 which will come soon. Firmware will be available for download from http://www.novexx.com/service-and-support/firmware/ upon release.	

It is not possible to use XLP 504 with LTSA in combination with other XLP options such as Rewinder 2000 or cutter.

4. Models and options

4.1. XLP 504 with LTSA applicator

The XLP 504 used in combination with a LTSA has some differences compared to a standard XLP 504:

- front part of the cover has a larger opening
- dispensing edge has no sensor like standard dispensing edge for XLP
- sub-D connector with cable tree at front side is configured differently compared to the similar parts as in a standard XLP 504 peripheral version
- M5A motor board is included (standard in XLP 504 peripheral version is a M4A motor board)

XLP 504 with LTSA is available for all print resolutions: 203, 300 and 600 dpi.

4.2. LTSA upgrade kit for XLP 504

We strongly recommend to order XLP 504 with LTSA as a complete unit from Eching. Nevertheless, an upgrade kit is available which includes the following components (see drawing):

- Applicator LTSA
- Front cover part
- Dispensing edge
- Sub-D connector + cable tree (different from connector known within peripheral version)
- M5A Motor board

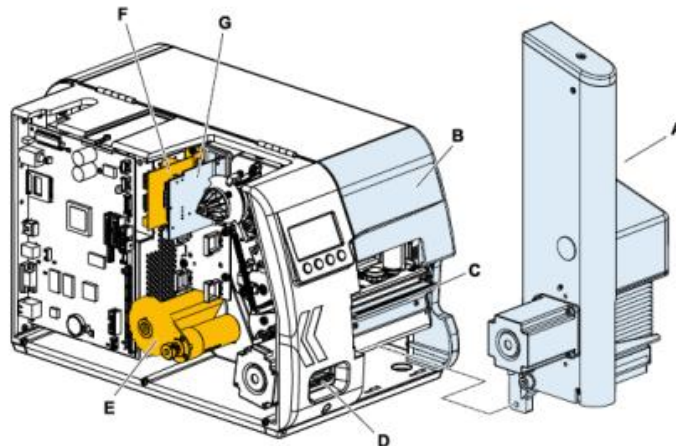

The LTSA upgrade kit can be used on XLP 504 with internal rewinder and dispensing edge, for basic and peripheral versions. Please note that firmware version V7.75 is required to run the LTSA.

When using the LTSA upgrade kit, some parts have to be exchanged and become obsolete:

PRINTER VERSION	ITEM NUMBER UPGRADE KIT	OBSOLETE PARTS AFTER INTEGRATION
XLP 504 Basic with internal rewinder and dispenser	N101196	Dispensing edge, front cover part
XLP 504 Peripheral with internal rewinder and dispenser		Dispensing edge, front cover part, M4A motor board, cable tree

In case of using the LTSA upgrade kit, we recommend to use XLP 504 basic with internal rewinder and dispenser since this results in the least obsolete parts.

4.3. Application activation methods

The LTSA application can be triggered through the following methods:

1. Using foot switch

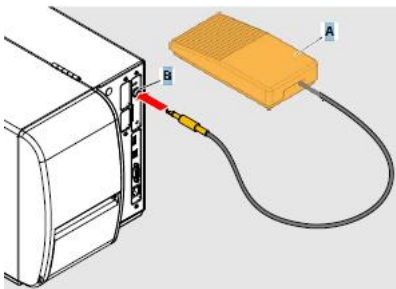

A foot switch is available as an option, part number A4053.

2. Using sensor

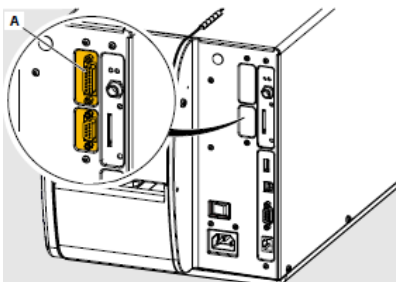

A sensor (e.g. product start sensor) with Sub-D- connector can be connected to the optional available I/O board (part numbers A6411/A4048).

5. Key applications

- printing & applying at picking stations (web shop logistics)
- shipment areas with varying packaging sizes, especially primary and secondary packaging
- printing & applying labels to sensitive products in low volume (e.g. food, jewelry)

6. Family positioning

XLP 504 LTSA is an extension within the XLP 50x range of label printers.

It is an addition to the NOVEXX Solutions semi-automatic Print & Apply solutions which also includes 64-0x printers with an LTSA applicator.

7. Item numbers and prices

7.1. Product

Item number	Description	Rec. end user price
N101168	XLP 504 basic 203 dpi with LTSA	€ 4,950
N101169	XLP 504 basic 300 dpi with LTSA	€ 5,200
N101172	XLP 504 basic 600 dpi with LTSA	€ 5,800

7.2. Options

N101196	LTSA Upgrade kit	€ 2,950
A6411 / A4048	I/O board (to connect product start sensor)	€ 235 / 215
A4053	Foot switch	€ 180

7.3. Demo unit

You can make use of one demo unit as follows:

N101169	XLP 504 basic 300 dpi with LTSA	€ 1,750
---------	---------------------------------	---------

8. State at delivery

XLP 504 with LTSA will be delivered as two components. The LTSA has to be installed and configured by a trained technician. Instructions can be found in the service manual LTSA.

9. Availability

XLP 504 with LTSA is now available.

10. Contact

Geert Jan Kolkhuis Tanke, Director Product Management
Email: geertjan.kolkhuistanke@novexx.com